

HP 200.1 TP



LEGENDA ESPLOSO • PART LIST • LEGENDE ECLATEE • LEYENDA EXPLOSO • ERSATZTEILLISTE

	I	GB	F	E	D		
POS.	DESCRIZIONE	DESCRIPTION	DESCRIPTION	DESCRIPCION	BESCHREIBUNG	PART. N°	QUANT.
101	BLOCCO QUADRO	CHUCK HOUSING-BARE	GUIDE AVANT-NUE	FONDO-DESNUDO	VORDERZ.-ALLEIN	0101010B	1
103	SPINA ELASTICA	ELASTIC PIN	GOIJON ELASTIQUE	PASADOR ELASTICO	STIFT FUER BUCHSE	330021	2
104	BOCCOLA D'IMPATTO	SPACER	ENTRETOISE D'ARRET	CASQUILLO SUPERIOR	MEISSELBUCHSE HINTEN	0201042	1
105	ANELLO DISTANZIALE	SPACER ENTRETOISE	BAGUE ENTRETOISE	ANILLO SEPARADOR	LIPPENDICHTUNGSHALTER	0101050	1
106	INGRASSATORE	GREASE NIPLE	GRAISSEUR	ENGRASADOR	SCHMIERNIPPEL	270021	1
108	FERMAUTENSILE	RETAINING AXLE	AXE DE RETENUE	RETENEDOR PICA	SPERRACHSE	0101080	2
110	SPINA ELASTICA	ELASTIC PIN	GOIJON ELASTIQUE	PASADOR ELASTICO	STIFT FUER BUCHSE	330141	2
117	O RING	O RING	JOINT TORIQUE	JUNTA TORICA	O RING	100122	4
152	BOCCOLA INF. WHISPER	CHUCK BUSK W	DOUILLE INFER. W	CASQUILLO INFER. W	MEISSELBUCHSE VORNE W	0201522	1
153	MANICOTTO ACCIAIO	COMPOSITE BUSH	DOUILLE SYNTETIQUE	MANGUITO	MUFFE	0101538	1
154	ANELLO D'ARRESTO	CIRCLIP	BAGUE	ANILLO DE BLOQUE	BLOCKIERUNGRING	0101540	1
201	CILINDRO	CYLINDER	CYLINDRE	CILINDRO	ZYLINDER	0102016	1
204	GUARN. A LABBRO	U JOINT	JOINT À LEVRES	JUNTA "U"	"U" DICHTUNG	110111	2
206	VALVOLINA	VALVE	SOUPAPE	VALVULA	VENTIL	0202062	3
209	PISTONE MASSA	PISTON	PISTON	PISTON	SCHLAGKOLBEN	0102096	1
210	RIDUZIONE DI GUIDA	GUIDE ADAPTER	DOUILLE DE CENTRAGE	ADAPTADOR GUIA	FUHERUNGSBUCHSE	0102105	1
211	SPINA RIFERIMENTO	PIN	GOUPILLE	PASADOR	STIFT	340091	1
301	TESTATA	HEAD	TETE	CABEZAL	KOPFTEIL	0103011	1
302	CORPO CASSETTO	DISTRIBUTOR BOX BODY	TIROIR DE DISTRIBUTION	CAJA DE DISTRIBUCION	STEUERGEHAEUSE	0103025	1
303	O RING	O RING	JOINT TORIQUE	JUNTA TORICA	O RING	100101	2
304	DISTRIBUTORE FAST	DISTRIBUTOR FAST	DISTRIBUTEUR FAST	DISTRIBUIDOR FAST	STEUERVENTIL FAST	0103048	1
305	COPERCHIO AMMORTIZZAT.	SHOCK ABSORBER COVER	COUVERCLE ARMOTISSEUR	TAPA AMMORTIGUADOR	DAMPFER VERTEILERSCHEIBE	0103051	1
306	DIAFRAMMA AMMORTIZZAT.	STEEL DIAPHRAGM	DIAPHRAGME ARMOTISSEUR	DIAFRAGMA AMORTIGUADOR	DAMPFER DIAPHRAGMA	0103061	1
307	TIRANTE CON GOMMA	SIDE BOLT-RUBBER	VIS TIRANT-CAOUTC	TIRANTE CAUCHO	SEITENSCHRAUBE-PLASTIK	0103070	4
308	DADO PER TIRANTE	NUT	ECROU	TUERCA	MUTTER	0303080	4
309	O RING	O RING	JOINT TORIQUE	JUNTA TORICA	O RING	100112	1
410	O RING	O RING	JOINT TORIQUE	JUNTA TORICA	O RING	100242	2
411	CILINDRETTO	BARREL	CANON	CUERPO	BUCHSE	0104111	1
412	PISTONCINO	SLIDE	PETIT PISTON	CORREDERA	VENTIL KOLBEN	0104121A	1
413	TAPPO GUIDA	GUIDING PLUG	BOUCHON GUIDE	TAPON GUIA	FUEHRUNGSTOPFEN	0104130	1
414	MOLLA	SPRING	RESSORT	MUELLE	FEDER	400131	1
415	CILINDRETTO DISTANZ.	SPACER BARREL	ENTRETOISE	SEPARADOR	DISTANZBUCHSE	0104150A	1
416	SPESSORE REGOLAZ.	ADJUSTMENT SHIM	RONDELLE DE CALAGE	LAMINA DE ADJUSTE	DISTANZBLECH	360031	11
417	O RING	O RING	JOINT TORIQUE	JUNTA TORICA	O RING	100121	1
501	MEZZA CAPSULA INF.	HALF LOWER SHELL	FLASQUE INFERIEUR	ALOJAMIENTO INFER.	AKKUM. KAPSEL-UNTEN	0205012	1
502	MEZZA CAPSULA SUP.	HALF UPPER SHELL	FLASQUE SUPERIEUR	ALOJAMIENTO SUP.	AKKUM. KAPSEL-OBEN	0105020	1
503	MEMBRANA (GOMMA)	DIAPHRAGM (RUBBER)	MEMBRANE (CAOUTC)	DIAFRAGMA (CAUCHO)	MEMBRANE (GUMMI)	0205030	1
504	VITE CARICA AZOTO	INFLATING SCREW	VIS DE GONFLAGE	TORNILLO DE INFLADO	FUELLSC. STICKSTOFF	0105040	1

HP 200.1 W / TP



LEGENDA ESPLOSO • PART LIST • LEGENDE ECLATEE • LEYENDA EXPLOSO • ERSATZTEILLISTE

	I	GB	F	E	D		
POS.	DESCRIZIONE	DESCRIPTION	DESCRIPTION	DESCRIPCION	BESCHREIBUNG	PART. N°	QUANT.
101	BLOCCO QUADRO	CHUCK HOUSING-BARE	GUIDE AVANT-NUE	FONDO-DESNUDO	VORDERZ.-ALLEIN	0101010B	1
103	SPINA ELASTICA	ELASTIC PIN	GOUJON ELASTIQUE	PASADOR ELASTICO	STIFT FUER BUCHSE	330021	2
104	BOCCOLA D'IMPATTO	SPACER	ENTRETOISE D'ARRET	CASQUILLO SUPERIOR	MEISSELBUCHSE HINTEN	0201042	1
105	ANELLO DISTANZIALE	SPACER ENTRETOISE	BAGUE ENTRETOISE	ANILLO SEPARADOR	LIPPENDICHTUNGSHALTER	0101050	1
106	INGRASSATORE	GREASE NIPLE	GRAISSEUR	ENGRASADOR	SCHMIERNIPPEL	270021	1
108	FERMAUTENSILE	RETAINING AXLE	AXE DE RETENUE	RETENEDOR PICA	SPERRACHSE	0101080	2
110	SPINA ELASTICA	ELASTIC PIN	GOUJON ELASTIQUE	PASADOR ELASTICO	STIFT FUER BUCHSE	330141	2
117	O RING	O RING	JOINT TORIQUE	JUNTA TORICA	O RING	100122	4
152	BOCCOLA INF. WHISPER	CHUCK BUSK W	DOUILLE INFER. W	CASQUILLO INFER. W	MEISSELBUCHSE VORNE W	0201522	1
153	MANICOTTO PLASTICA	COMPOSITE BUSH	DOUILLE SYNTETIQUE	MANGUITO	MUFFE	0101530	1
154	ANELLO D'ARRESTO	CIRCLIP	BAGUE	ANILLO DE BLOQUE	BLOCKIERUNGRING	0101540	1
201	CILINDRO	CYLINDER	CYLINDRE	CILINDRO	ZYLINDER	0102016	1
204	GUARN. A LABBRO	U JOINT	JOINT À LEVRES	JUNTA "U"	"U" DICHTUNG	110111	2
206	VALVOLINA	VALVE	SOUPAPE	VALVULA	VENTIL	0202062	3
209	PISTONE MASSA	PISTON	PISTON	PISTON	SCHLAGKOLBEN	0102096	1
210	RIDUZIONE DI GUIDA	GUIDE ADAPTER	DOUILLE DE CENTRAGE	ADAPTADOR GUIA	FUHERUNGSBUCHSE	0102105	1
211	SPINA RIFERIMENTO	PIN	GOUPILLE	PASADOR	STIFT	340091	1
301	TESTATA	HEAD	TETE	CABEZAL	KOPFTEIL	0103011	1
302	CORPO CASSETTO	DISTRIBUTOR BOX BODY	TIROIR DE DISTRIBUTION	CAJA DE DISTRIBUCION	STEUERGEHAEUSE	0103025	1
303	O RING	O RING	JOINT TORIQUE	JUNTA TORICA	O RING	100101	2
304	DISTRIBUTORE FAST	DISTRIBUTOR FAST	DISTRIBUTEUR FAST	DISTRIBUIDOR FAST	STEUERVENTIL FAST	0103048	1
305	COPERCHIO AMMORTIZZAT.	SHOCK ABSORBER COVER	COUVERCLE ARMOTISSEUR	TAPA AMMORTIGUADOR	DAMPFER VERTEILERSCHEIBE	0103051	1
306	DIAFRAMMA AMMORTIZZAT.	STEEL DIAPHRAGM	DIAPHRAGME ARMOTISSEUR	DIAFRAGMA AMORTIGUADOR	DAMPFER DIAPHRAGMA	0103061	1
307	TIRANTE CON GOMMA	SIDE BOLT-RUBBER	VIS TIRANT-CAOUTC	TIRANTE CAUCHO	SEITENSCHRAUBE-PLASTIK	0103070	4
308	DADO PER TIRANTE	NUT	ECROU	TUERCA	MUTTER	0303080	4
309	O RING	O RING	JOINT TORIQUE	JUNTA TORICA	O RING	100112	1
410	O RING	O RING	JOINT TORIQUE	JUNTA TORICA	O RING	100242	2
411	CILINDRETTO	BARREL	CANON	CUERPO	BUCHSE	0104111	1
412	PISTONCINO	SLIDE	PETIT PISTON	CORREDERA	VENTIL KOLBEN	0104121A	1
413	TAPPO GUIDA	GUIDING PLUG	BOUCHON GUIDE	TAPON GUIA	FUEHRUNGSTOPFEN	0104130	1
414	MOLLA	SPRING	RESSORT	MUELLE	FEDER	400131	1
415	CILINDRETTO DISTANZ.	SPACER BARREL	ENTRETOISE	SEPARADOR	DISTANZBUCHSE	0104150A	1
416	SPESSORE REGOLAZ.	ADJUSTMENT SHIM	RONDELLE DE CALAGE	LAMINA DE ADJUSTE	DISTANZBLECH	360031	11
417	O RING	O RING	JOINT TORIQUE	JUNTA TORICA	O RING	100121	1
501	MEZZA CAPSULA INF.	HALF LOWER SHELL	FLASQUE INFERIEUR	ALOJAMIENTO INFER.	AKKUM. KAPSEL-UNTEN	0205012	1
502	MEZZA CAPSULA SUP.	HALF UPPER SHELL	FLASQUE SUPERIEUR	ALOJAMIENTO SUP.	AKKUM. KAPSEL-OBEN	0105020	1
503	MEMBRANA (GOMMA)	DIAPHRAGM (RUBBER)	MEMBRANE (CAOUTC)	DIAFRAGMA (CAUCHO)	MEMBRANE (GUMMI)	0205030	1
504	VITE CARICA AZOTO	INFLATING SCREW	VIS DE GONFLAGE	TORNILLO DE INFLADO	FUELLSC. STICKSTOFF	0105040	1

HP 200.1 - HP 200.1 W



ESPLOSO • EXPLODED VIEW • NUE ECLATEE • EXPLOSO • ERSATZTEIL-ZEICHNEN

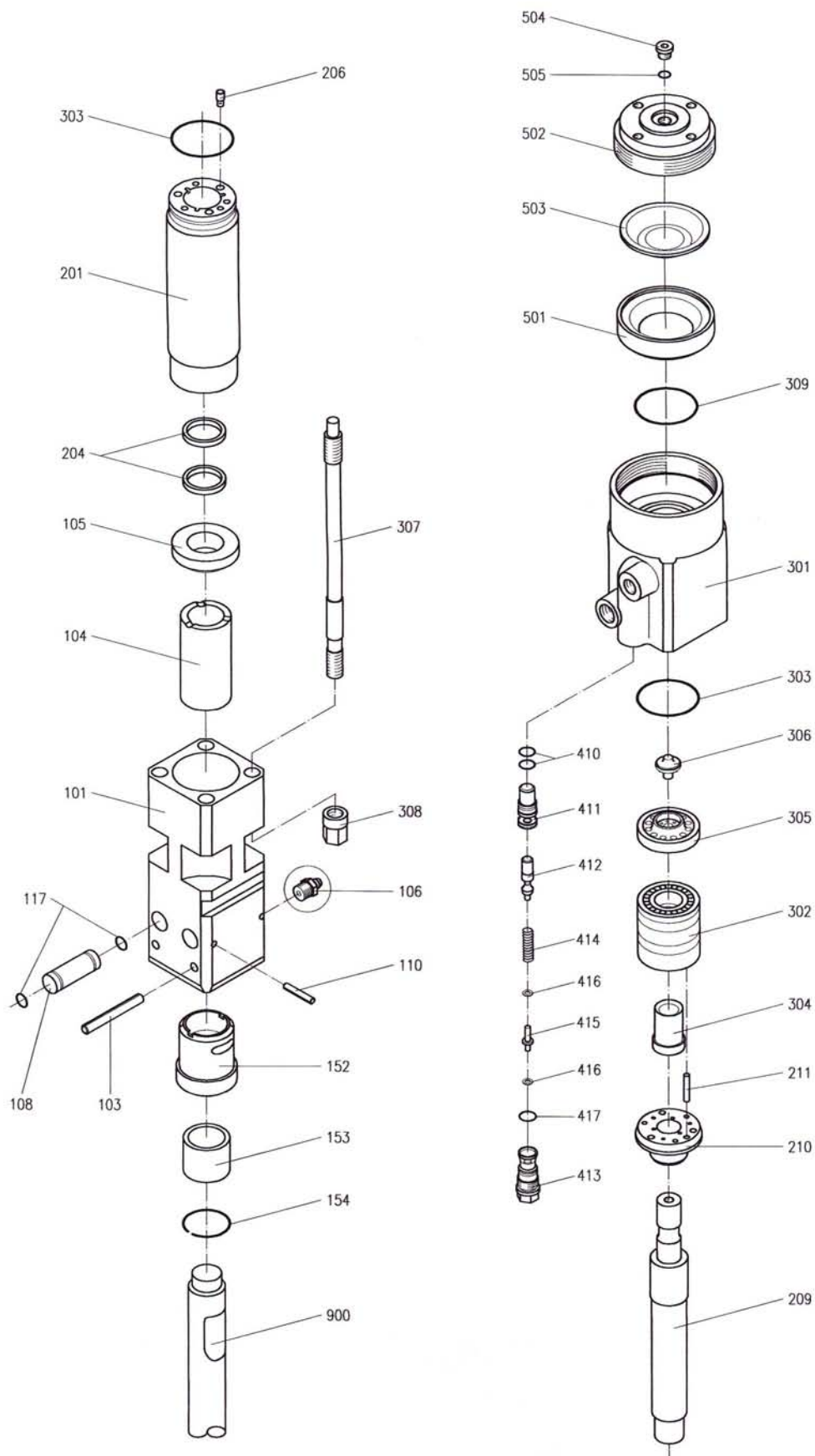

HP 200.1 TP



ESPLOSO • EXPLODED VIEW • NUE ECLATEE • EXPLOSO • ERSATZTEIL-ZEICHNEN

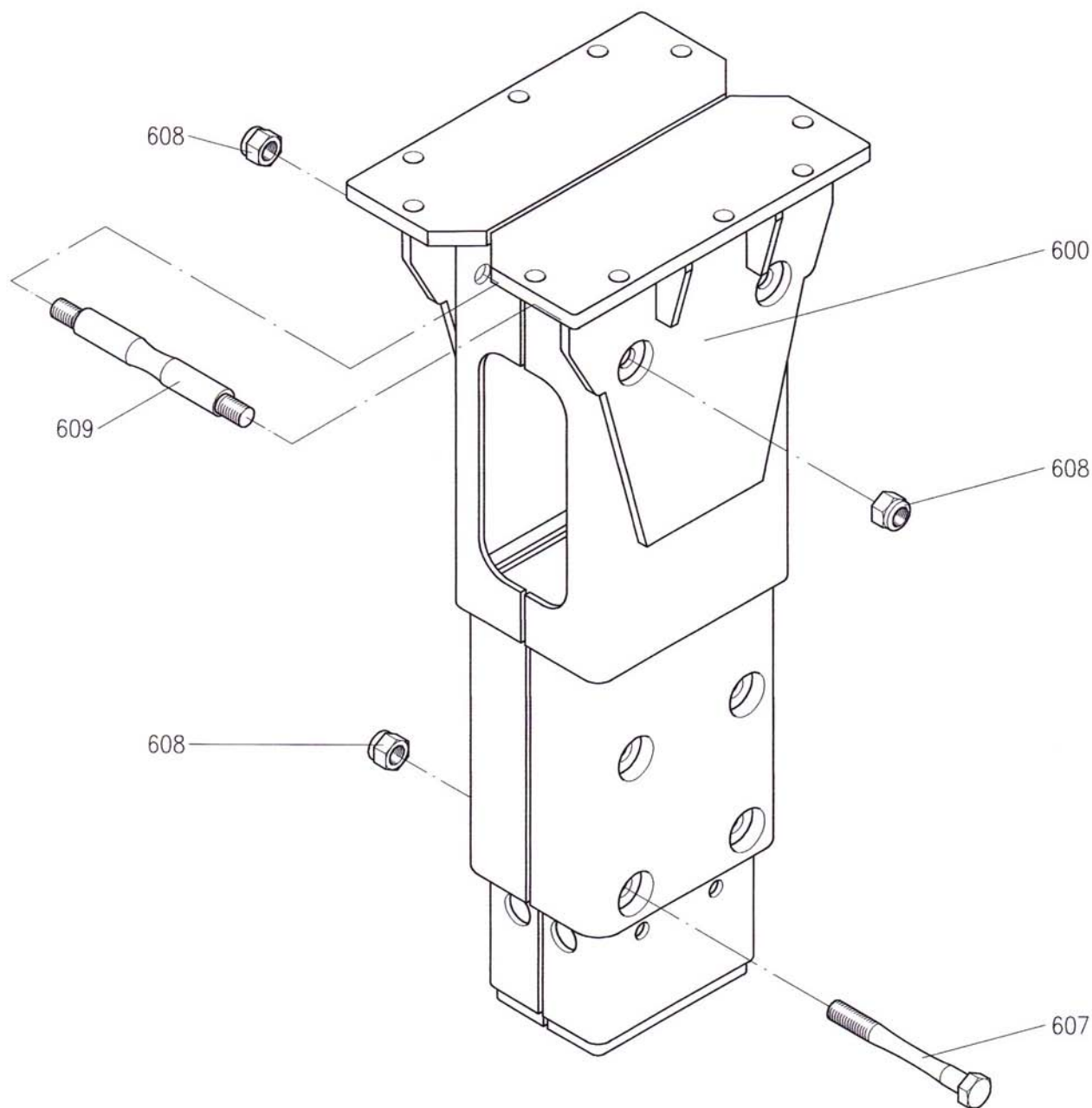

HP 200.1 W / TP



ESPLOSO • EXPLODED VIEW • NUE ECLATEE • EXPLOSO • ERSATZTEIL-ZEICHNEN

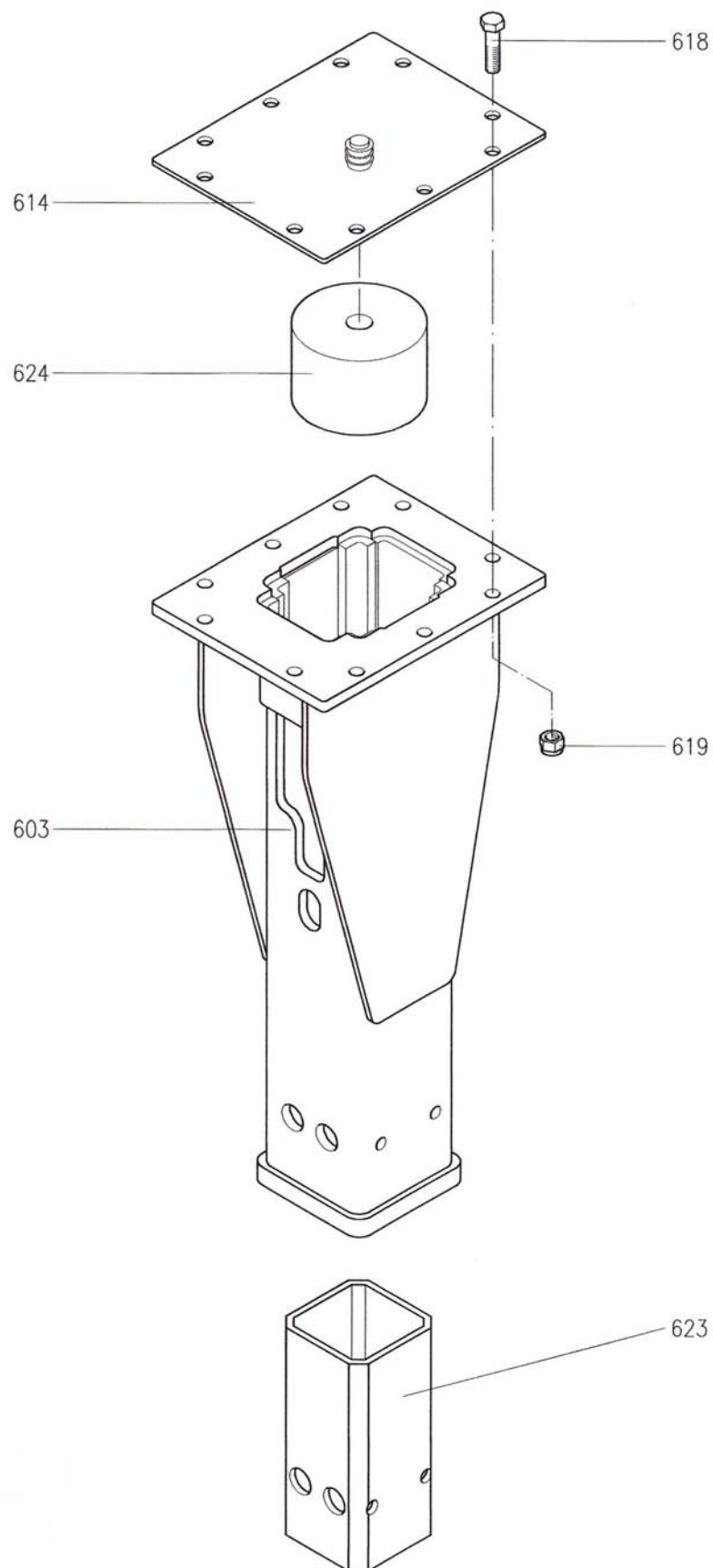

HP 200.1 TP



SPECIFICA TECNICA • TECHNICAL SPECIFICATION • SPECIFICATION TECHNIQUE • NOTA TECNICA • TECHNISCHE SPEZIFIKATION

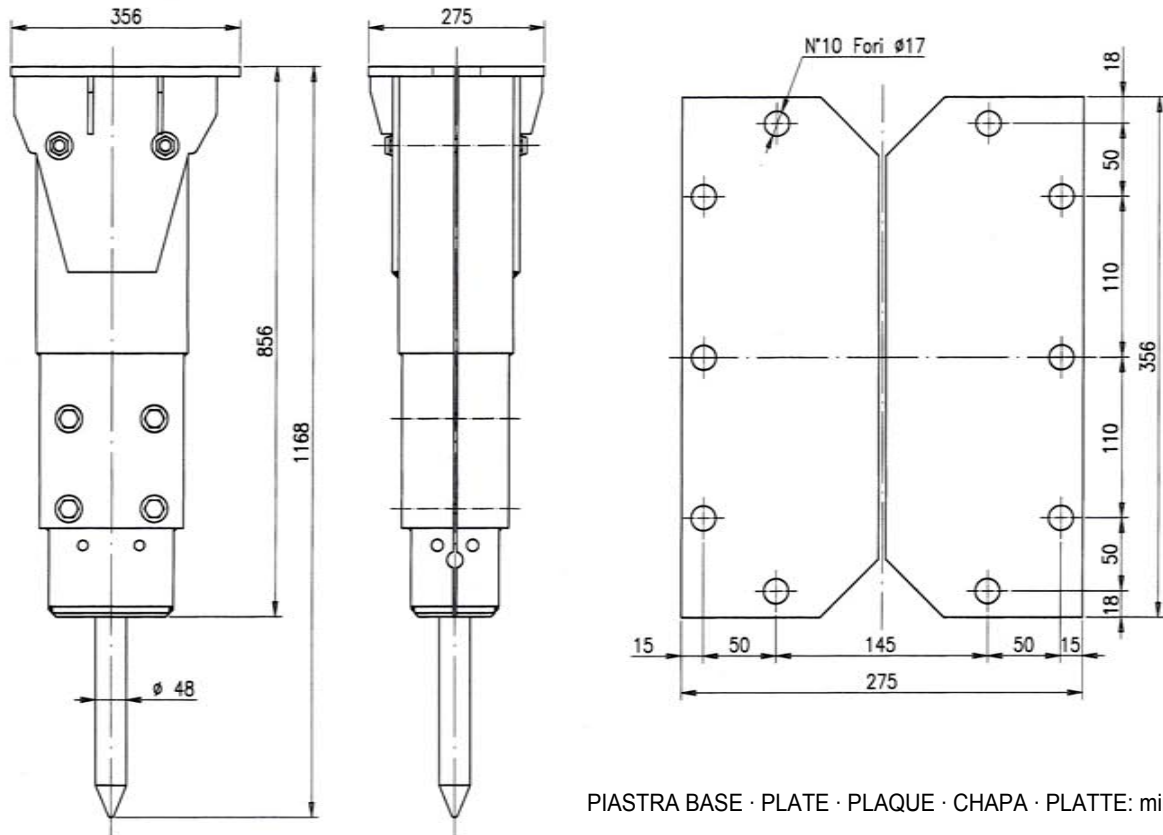

PIASTRA BASE · PLATE · PLAQUE · CHAPA · PLATTE: min. 15mm

I	GB	F	E	D	
PESO ESCAVATORE	SUITABLE ESCAVATOR	POIDS PELLE	PESO EXCAVADORA	GEEIGNET FÜR TRÄGERGERÄT	1,4 ÷ 5 ton
PESO OPERATIVO (CON SELLA E UTENSILE)	OPERATING WEIGHT (WITH MOUNTING BRACKET AND TOOL)	POIDS OPERATION (AVEC PLATINE ET OUTIL)	PESO OPERATIVO (CON CABEZAL E UTIL)	ARBEITSGEWICHT DES HAMMERS (MIT ADAPTERPLATTE UND MEISSEL)	130 kg
PESO (SENZA SELLA E UTENSILE)	OPERATING WEIGHT (WITHOUT MOUNTING BRACKET AND TOOL)	POIDS OPERATION (SANS PLATINE ET OUTIL)	PESO OPERATIVO (SIN CABEZAL E UTIL)	ARBEITSGEWICHT DES HAMMERS (OHNE ADAPTERPLATTE UND MEISSEL)	115 kg
DIAMETRO UTENSILE	STEEL DIAMETER	DIAMETRE OUTIL	DIAMETRO DE LA HERRAMIENTA	MEISSELDURCHMESSER	48 mm
ATTACCHI AL MARTELLO ENTRATA	HOSE CONNECTION AT THE BREAKERS INLET LINE	JOINTAGE AU BRISEROCHE ENTREE	DIAMETRO DE LA CONEXION ENTRADA AL MARTILLO	HAMMER-ANSCHLUSSSCHLAUCH VORLAUF	1/2" Gas
ATTACCHI AL MARTELLO USCITA	HOSE CONNECTION AT THE BREAKERS RETURN LINE	JOINTAGE AU BRISEROCHE SORTIE	DIAMETRO DE LA CONEXION SAIDA AL MARTILLO	HAMMER-ANSCHLUSSSCHLAUCH BÜCKLAUF	3/4" Gas
TUBAZIONE IMPIANTO (raccom.) TUBO MANDATA (min. in dia)	INLET LINE SIZE RECOMMENDATION (min.)	DIAMETRE TUYAN H.P. (min.)	DIAMETRO TUBO DE ENTRADA (min.)	VORLAUF-LEITUNGSGRÖSSE EMPFOHLEN (min.)	10 mm
TUBAZIONE IMPIANTO (raccom.) TUBO RITORNO (min. in dia)	RETURN LINE SIZE RECOMMENDATION (min.)	DIAMETRE TUYAN B.P. (min.)	DIAMETRO TUBO DE DESCARGA (min.)	RÜCKLAUF-LEITUNGSGRÖSSE EMPFOHLEN (min.)	12 mm
PORTATA DA EROGARE	OIL SUPPLY	DEBIT AU BRISEROCHE	CAUDAL DA SUMINISTRAR	ÖLBEDARF	25 ÷ 45 l/min
PRESSIONE REGOLATA AL MARTELLO	BREAKER WORKING PRESSURE	PRESSION REGLEE AU BRISE ROCHE	PRESION REGULADA AL MARTILLO	ARBEITSÖLDRUCK IM HYDRAULIKHAMMER	105 ÷ 125 bar
PRESSIONE REGOLATA ALL'ESCAVATORE	RELIEF PRESSURE SETTING	PRESSION REGLEE A LA PELLE	PRESION REGULADA A LA EXCAVADORA	ARBEITSÖLDRUCK VOM TRÄGERGERÄT	160 bar
CONTROPRESSIONE SUL MARTELLO (MAX)	BACK-PRESSURE AT THE BREAKER (MAX)	CONTRE PRESSION AU BRISE ROCHE (MAX)	CONTRAPRESION AL MARTILLO (MAX)	RÜCKLAUF-STAUDRUCK AM HYDRAULIKHAMMER (MAX)	11 bar
ENERGIA D'URTO (MAX)	IMPACT ENERGY (MAX)	PUISSANCE DE CHOC (MAX)	ENERGIA DE CHOQUE (MAX)	EINZELSCHLAG-ENERGIE (MAX)	240 Joule
NUMERO COLPI AL MINUTO	IMPACT RATE	FRAPPES PAR MINUTE	GOLPES AL MINUTO	SCHLAGZAHL PRO MINUTE	700 ÷ 1800 n/min
POTENZA INGRESSO (MAX)	INPUT POWER (MAX)	PUISSANCE ENTREE (MAX)	POTENCIA ENTRADA (MAX)	EINGANGS-GEWALT (MAX)	7 kw
VISCOSITÀ OLIO IDRAULICO	HYDRAULIC OIL VISCOSITY	VISCOSITE DE L'HUILE HIDR.	VISCOSODAD DELACEITE HIDR.	VISKOSITÄT DES HYDRAULIKÖLES	15 ÷ 90 Cst
LUNGHEZZA SUGGERITA TUBI FLESSIBILI	SUGGESTED MIN FLEX HOSES LENGHT	LONGUEUR DES FLEXIBLES	LARG. TUBOS FLEXIBLES	HAMMER-ANSCHLUSSSCHLAUCH LANGE	1200 mm

HP 200.1 W / TP



SPECIFICA TECNICA • TECHNICAL SPECIFICATION • SPECIFICATION TECHNIQUE • NOTA TECNICA • TECHNISCHE SPEZIFIKATION

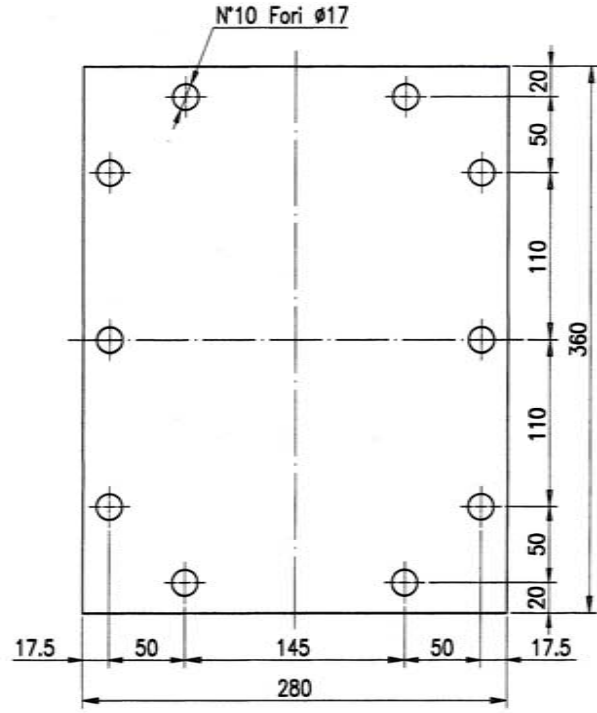
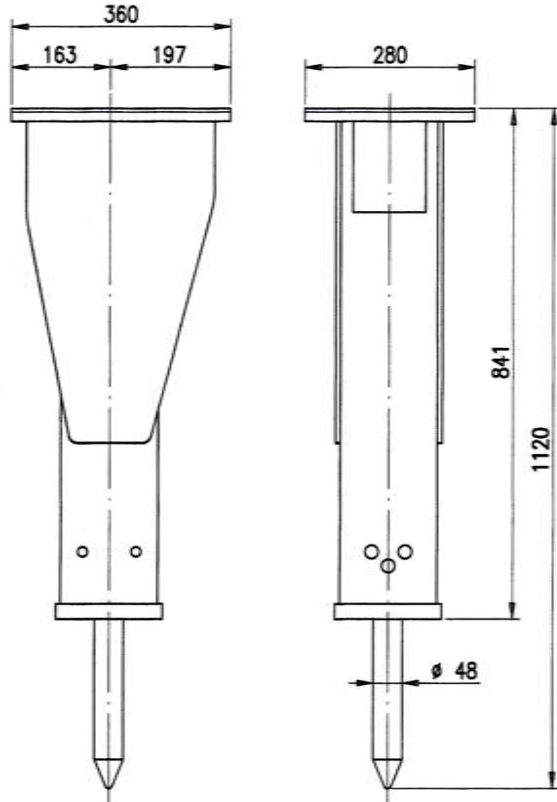

PIASTRA BASE · PLATE · PLAQUE · CHAPA · PLATTE: min. 15mm

I	GB	F	E	D	
PESO ESCAVATORE	SUITABLE ESCAVATOR	POIDS PELLE	PESO EXCAVADORA	GEEIGNET FÜR TRÄGERGERÄT	1,4 ÷ 5 ton
PESO OPERATIVO (CON SELLA E UTENSILE)	OPERATING WEIGHT (WITH MOUNTING BRACKET AND TOOL)	POIDS OPERATION (AVEC PLATINE ET OUTIL)	PESO OPERATIVO (CON CABEZAL E UTIL)	ARBEITSGEWICHT DES HAMMERS (MIT ADAPTERPLATTE UND MEISSEL)	160 kg
PESO (SENZA SELLA E UTENSILE)	OPERATING WEIGHT (WITHOUT MOUNTING BRACKET AND TOOL)	POIDS OPERATION (SANS PLATINE ET OUTIL)	PESO OPERATIVO (SIN CABEZAL E UTIL)	ARBEITSGEWICHT DES HAMMERS (OHNE ADAPTERPLATTE UND MEISSEL)	130 kg
DIAMETRO UTENSILE	STEEL DIAMETER	DIAMETRE OUTIL	DIAMETRO DE LA HERRAMIENTA	MEISSELDURCHMESSER	48 mm
ATTACCHI AL MARTELLO ENTRATA	HOSE CONNECTION AT THE BREAKERS INLET LINE	JOINTAGE AU BRISEROCHE ENTREE	DIAMETRO DE LA CONEXION ENTRADA AL MARTILLO	HAMMER-ANSCHLUSSSCHLAUCH VORLAUF	1/2" Gas
ATTACCHI AL MARTELLO USCITA	HOSE CONNECTION AT THE BREAKERS RETURN LINE	JOINTAGE AU BRISEROCHE SORTIE	DIAMETRO DE LA CONEXION SAIDA AL MARTILLO	HAMMER-ANSCHLUSSSCHLAUCH BÜCKLAUF	3/4" Gas
TUBAZIONE IMPIANTO (raccom.) TUBO MANDATA (min. in dia)	INLET LINE SIZE RECOMMENDATION (min.)	DIAMETRE TUYAN H.P. (min.)	DIAMETRO TUBO DE ENTRADA (min.)	VORLAUF-LEITUNGSGRÖSSE EMPFOHLEN (min.)	10 mm
TUBAZIONE IMPIANTO (raccom.) TUBO RITORNO (min. in dia)	RETURN LINE SIZE RECOMMENDATION (min.)	DIAMETRE TUYAN B.P. (min.)	DIAMETRO TUBO DE DESCARGA (min.)	RÜCKLAUF-LEITUNGSGRÖSSE EMPFOHLEN (min.)	12 mm
PORTATA DA EROGARE	OIL SUPPLY	DEBIT AU BRISEROCHE	CAUDAL DA SUMINISTRAR	ÖLBEDARF	25 ÷ 45 l/min
PRESSIONE REGOLATA AL MARTELLO	BREAKER WORKING PRESSURE	PRESSION REGLEE AU BRISE ROCHE	PRESION REGULADA AL MARTILLO	ARBEITSÖLDRUCK IM HYDRAULIKHAMMER	105 ÷ 125 bar
PRESSIONE REGOLATA ALL'ESCAVATORE	RELIEF PRESSURE SETTING	PRESSION REGLEE A LA PELLE	PRESION REGULADA A LA EXCAVADORA	ARBEITSÖLDRUCK VOM TRÄGERGERÄT	160 bar
CONTROPRESSIONE SUL MARTELLO (MAX)	BACK-PRESSURE AT THE BREAKER (MAX)	CONTRE PRESSION AU BRISE ROCHE (MAX)	CONTRAPRESION AL MARTILLO (MAX)	RÜCKLAUF-STAUDRUCK AM HYDRAULIKHAMMER (MAX)	11 bar
ENERGIA D'URTO (MAX)	IMPACT ENERGY (MAX)	PUISSANCE DE CHOC (MAX)	ENERGIA DE CHOQUE (MAX)	EINZELSCHLAG-ENERGIE (MAX)	240 Joule
NUMERO COLPI AL MINUTO	IMPACT RATE	FRAPPES PAR MINUTE	GOLPES AL MINUTO	SCHLAGZAHL PRO MINUTE	700 ÷ 1800 n/min
POTENZA INGRESSO (MAX)	INPUT POWER (MAX)	PUISSANCE ENTREE (MAX)	POTENCIA ENTRADA (MAX)	EINGANGS-GEWALT (MAX)	7 kw
VISCOSITÀ OLIO IDRAULICO	HYDRAULIC OIL VISCOSITY	VISCOSITE DE L'HUILE HIDR.	VISCOSIDAD DELACEITE HIDR.	VISKOSITÄT DES HYDRAULIKÖLES	15 ÷ 90 Cst
LUNGHEZZA SUGGERITA TUBI FLESSIBILI	SUGGESTED MIN FLEX HOSES LENGHT	LONGUEUR DES FLEXIBLES	LARG. TUBOS FLEXIBLES	HAMMER-ANSCHLUSSSCHLAUCH LANGE	1200 mm

HP 200.1



COPPIE DI SERRAGGIO VITI E PRESSIONE CARICA AZOTO • TORQUE SETTING SCREWS AND NITROGEN CHARGING PRESSURE • COUPLE SERRAGE DES VIS ET PRESSION GONFLAGE AZOTE • PAR DE TORSION TORNILLOS Y PRESION CARGA DE NITROGENO • ANZUG DREHI MOMENT LADEN DRUCK STICKSTOFF

I	GB	F	E	D			
PARTICOLARE	PART	COMPOSANTE	PARTES	BESTANDTEIL	POS.	KEY	MKG
DADO	NUT	ECROU	TUERCA	NUTTER	308	27	28*
VITE VALVOLA PRESSIONE	GUIDING PLUG	BOUCHON GUIDE	TAPON GUIA	STOPFEN	413	24	30
VITE CARICA AZOTO	INFLATING SCREW	VIS DE GONFLAGE	TORNILLO PARA INFLAR	FUELLSCHRAUBE STICKSTOFF	504	B 8	9
ANCORAGGIO SEMICAPSULA	HALF UPPER SHELL	FLASQUE SUPERIEUR	ALOJAMENTO SUPERIOR	AKKUMULATOR-KAPSEL OBEN	502	INDECO	80
VITE ATTACCO SELLA	CRADLE SCREW	VIS POUR CHAPEAU	TORNILLO	SCHRAUBE FUER SATTEL	618	22	20
VITE CHIUSURA CARCASSA	SCREW	VIS	TORNILLO	SCHRAUBE	607	27	30
DADO DISTANZIALE CARCASSA	SELF-LOCKING NUT	ENTRETOISE CARCASSE	TUERCA AUTOBLOCANTE	SCHRAUBEN-MUTTER	608	27	20
PRESS. CARICA AZOTO OLIO 60°C	NITROGEN CHARGING PRESS. (AT OIL TEMP. 60°C)	PRESS. GONFLAGE AZOTE (TEMP. HUILE 60° C)	PRESION CARGA DE NITROGENO (ACEITE TEMP. 60° C)	LADEN DRUCK STICKSTOFF (OL TEMP. 60° C)	35 bars		
PRESS. CARICA AZOTO OLIO 70°C	NITROGEN CHARGING PRESS. (AT OIL TEMP. 70°C)	PRESS. GONFLAGE AZOTE (TEMP. HUILE 70° C)	PRESION CARGA DE NITROGENO (ACEITE TEMP. 70° C)	LADEN DRUCK STICKSTOFF (OL TEMP. 70° C)	30 bars		

* Il valore di coppia deve essere raggiunto gradatamente in più fasi di avvitamento e serrando a croce ed a rotazione.

* The indicated torque value must be reached gradually, screwing up the bolts in several phases by cross tightening and rotation.

* On doit atteindre la valeur de couple indiquée de manière graduelle, en plusieurs phases de vissage et en serrant à l'aide d'un tournevis en croix en plusieurs tours.

* El valor de acoplamiento indicado debe alcanzarse gradualmente atornillando en varias fases y apretando en forma de cruz y con un movimiento de rotación.

* Der Wert des Drehmomentes muss stufenweise in mehreren Verschraubungsphasen erreicht werden, indem Sie überkreuz und in Drehrichtung anschrauben.

HP 200.1 TP



LISTA COMPONENTI AGGIUNTIVI • PART LIST ACCESSORIES • LISTE DE LES ACCESSOIRES • LISTA DE COMPONENTES ADICIONAL • LISTE BAUELEMENT ZUSATZLICH

	I	GB	F	E	D		
POS.	DESCRIZIONE	DESCRIPTION	DESCRIPTION	DESCRIPCION	BESCHREIBUNG	PART. N°	QUANT.
	SELLA	CRADLE	PLATINE	CABEZAL	SATTEL	0220000	
618	VITE ATTACCO SELLA	CRADLE SCREW	VIS POUR CHAPEAU	TORNILLO	SCHRAUBE FUER SATTEL	310361	10
619	DADO AUTOBLOCCANTE	SELF LOCKING NUT	ECROU DE SURETE	TUERCA AUTOBLOCANTE	SCHRAUBENNUTTER	320091	10
	UTENSILE SCALPELLO	CHISEL	BURIN	CINCEL	FLACHMEISSEL	0209011AV	
	UTENSILE CONO	MOIL POINT	PIC	PICA	KEGELSPITZE	0209101AV	
	UTENSILE COBRA	COBRA TOOL	OUTIL COBRA	UTIL COBRA	COBRA MEISSEL		
	UTENSILE	TOOL	OUTIL	UTIL	MEISSEL		
	KIT INGRASSAGGIO	KIT AUTOLUBE	KIT DE GRAISSAGE	KIT DE ENGRASE	SCHMIERZENTRALE		
	KIT SUB	KIT UNDER WATER	KIT SOUS MARINE	KIT SUBMARINO	KIT UNTERWASSER		
	KIT CARICA AZOTO	NITROGEN INFLATING KIT	KIT LE GONFLAGE	EQUIPO CARGA NITROGENO	STICKSTOFF SPEICHLR	2720000C	
	ELETTROVALVOLA	SOLENOID VALVE	SOUPAPE ELECTRIQUE	ELECTRO VALVULA	ELEKTRISCHER VENTIL		
	PEDALIERA	FOOT SWITCH	INTERRUPTEUR À PEDAL	INTERRUPTOR DE PIE	FUSSGEBER		
	KIT IDRAULICO	HYDRAULIC KIT	KIT HYDRAULIQUE	KIT HIDRAULICO	HYDRAULIK ANSCHLUSS		
	TUBO MANDATA DEMOLITORE	INLET PIPE	TUYAN H.P.	TUBO DE ALIMENTACION	HD-SCHLÄUCHE	500021	
	TUBO RITORNO DEMOLITORE	OUT LET PIPE	TUYAN B.P.	ND-SCHLÄUCHE	ND-SCHLÄUCHE	500102	

HP 200.1 W / TP



LISTA COMPONENTI AGGIUNTIVI • PART LIST ACCESSORIES • LISTE DE LES ACCESSOIRES • LISTA DE COMPONENTES ADICIONAL • LISTE BAUELEMENT ZUSATZLICH

	I	GB	F	E	D		
POS.	DESCRIZIONE	DESCRIPTION	DESCRIPTION	DESCRIPCION	BESCHREIBUNG	PART. N°	QUANT.
	SELLA	CRADLE	PLATINE	CABEZAL	SATTEL	0220000	
618	VITE ATTACCO SELLA	CRADLE SCREW	VIS POUR CHAPEAU	TORNILLO	SCHRAUBE FUER SATTEL	310421	10
619	DADO AUTOBLOCCANTE	SELF LOCKING NUT	ECROU DE SURETE	TUERCA AUTOBLOCANTE	SCHRAUBENNUTTER	320091	10
	UTENSILE SCALPELLO	CHISEL	BURIN	CINCEL	FLACHMEISSEL	0209011AV	
	UTENSILE CONO	MOIL POINT	PIC	PICA	KEGELSPITZE	0209101AV	
	UTENSILE COBRA	COBRA TOOL	OUTIL COBRA	UTIL COBRA	COBRA MEISSEL		
	UTENSILE	TOOL	OUTIL	UTIL	MEISSEL		
	KIT INGRASSAGGIO	KIT AUTOLUBE	KIT DE GRAISSAGE	KIT DE ENGRASE	SCHMIERZENTRALE		
	KIT SUB	KIT UNDER WATER	KIT SOUS MARINE	KIT SUBMARINO	KIT UNTERWASSER		
	KIT CARICA AZOTO	NITROGEN INFLATING KIT	KIT LE GONFLAGE	EQUIPO CARGA NITROGENO	STICKSTOFF SPEICHLR	2720000C	
	ELETTROVALVOLA	SOLENOID VALVE	SOUPAPE ELECTRIQUE	ELECTRO VALVULA	ELEKTRISCHER VENTIL		
	PEDALIERA	FOOT SWITCH	INTERRUPTEUR À PEDAL	INTERRUPTOR DE PIE	FUSSGEBER		
	KIT IDRAULICO	HYDRAULIC KIT	KIT HYDRAULIQUE	KIT HIDRAULICO	HYDRAULIK ANSCHLUSS		
	TUBO MANDATA DEMOLITORE	INLET PIPE	TUYAN H.P.	TUBO DE ALIMENTACION	HD-SCHLÄUCHE	500021	
	TUBO RITORNO DEMOLITORE	OUT LET PIPE	TUYAN B.P.	ND-SCHLÄUCHE	ND-SCHLÄUCHE	500102	