

HP 600.1 TP



LEGENDA ESPLOSO • PART LIST • LEGENDE ECLATEE • LEYENDA EXPLOSO • ERSATZTEILLISTE

	I	GB	F	E	D		
POS.	DESCRIZIONE	DESCRIPTION	DESCRIPTION	DESCRIPCION	BESCHREIBUNG	PART. N°	QUANT.
101	BLOCCO QUADRO	CHUCK HOUSING-BARE	GUIDE AVANT-NUE	FONDO-DESNUDO	VORDERZ.-ALLEIN	0701010A	1
103	SPINA ELASTICA	ELASTIC PIN	GOUJON ELASTIQUE	PASADOR ELASTICO	STIFT FUER BUCHSE	330071	2
104	BOCCOLA D'IMPATTO	SPACER	ENTRETOISE D'ARRET	CASQUILLO SUPERIOR	MEISSELBUCHSE HINTEN	0501040	1
106	INGRASSATORE	GREASE NIPPLE	GRAISSEUR	ENGRASADOR	SCHMIERNIPPEL	270011	1
108	FERMAUTENSILE	RETAINING AXLE	AXE DE RETENUE	RETENEDOR PICA	SPERRACHSE	0701081	2
110	SPINA ELASTICA	ELASTIC PIN	GOUJON ELASTIQUE	PASADOR ELASTICO	STIFT FUER BUCHSE	330121	1
117	O RING	O RING	JOINT TORIQUE	JUNTA TORICA	O RING	100173	4
152	BOCCOLA INF. WHISPER	CHUCK BUSH W	DOUILLE INFER. W	CASQUILLO INFER. W	MEISSELBUCHSE W	2301520	1
153	MANICOTTO ACCIAIO	STEEL INSERT BUSH	DOUILLE EN ACIER	MANGUITO (ACERO)	MUFFE (STAHL)	2301538	1
154	ANELLO D'ARRESTO	CIRCLIP	BAGUE	ANILLO DE BLOQUE	BLOCKIERUNG RING	2301540	1
201	CILINDRO	CYLINDER	CYLINDRE	CILINDRO	ZYLINDER	0702016	1
204	GUARN. A LABBRO	"U" JOINT	JOINT À LEVRES	JUNTA "U"	"U" DICHTUNG	110031	2
206	VALVOLINA	VALVE	SOUPAPE	VALVULA	VENTIL	0302061	3
209	PISTONE MASSA	PISTON	PISTON	PISTON	SCHLAGKOLBEN	0702096	1
210	RIDUZIONE DI GUIDA	GUIDE ADAPTER	DOUILLE DE CENTRAGE	ADAPTADOR GUIA	FUHERUNGSBUCHSE	0702105	1
211	SPINA RIFERIMENTO	CENTERING PIN	GOUPILLE	PASADOR	STIFT	340121	1
301	TESTATA	HEAD	TETE	CABEZAL	KOPFTEIL	0703011	1
302	CORPO CASSETTO	DISTRIBUTOR BOX BODY	TIROIR DE DISTRIBUT.	CAJA DE DISTRIBUCION	STEUERGEHAUSE	0703025	1
303	O RING	O RING	JOINT TORIQUE	JUNTA TORICA	O RING	100151	2
304	DISTRIBUTORE FAST	DISTRIBUTOR FAST	DISTRIBUTEUR FAST	DISTRIBUIDOR FAST	STEUERVENTIL FAST	0703043	1
305	COPERCHIO AMMORTIZZAT.	SHOCK ABSORBER COVER	COUVERCLE ARMOTISSEUR	TAPA AMMORTIGUADOR	DAMPFER VERTEILERSCHEIBE	0703051	1
306	DIAFRAMMA AMMORTIZZAT.	STEEL DIAPHRAGM	DIAPHRAGME ARMOTISSEUR	DIAFRAGMA AMORTIGUADOR	DAMPFER DIAPHRAGMA	0703060	1
307	TIRANTE CON GOMMA	SIDE BOLT-RUBBER	VIS TIRANT-CAOUTC.	TIRANTE GOMA	SEITENSCHRAUBE-PLASTIK	0501140A	4
308	DADO PER TIRANTE	NUT	ECROU	TUERCA	MUTTER	0501130	4
309	O RING	O RING	JOINT TORIQUE	JUNTA TORICA	O RING	100112	1
401	ATTACCO	LINK	RACCORD	CONEXION	ANSCHLUSS-GEHAUSE	0604010	2
402	RONDELLA DI TENUTA	SEALING WASHER	RONDELLE D'ETANCHE	ANILLO DE SELLADO	DICHTUNGSSCHEIBE	120011	2
403	TAPPO 1/4" GAS	PLUG 1/4" GAS	BOUCHON 1/4" GAS	TAPON 1/4" GAS	STOPFEN 1/4" GAS	200011	2
404	RACCORDO 3/4"	CONNECTION 3/4"	RACCORD 3/4"	CONEXION 3/4"	3/4" ANSCHLUSS	1207140	2
406	O RING	O RING	JOINT TORIQUE	JUNTA TORICA	O RING	100032	4
407	RONDELLA	WASHER	RONDELLE	ARANDELA	SCHEIBE	1207190	2
408	SEEGER	SEEGER	SEEGER	RETENEDOR SEEGER	SPRENGRING	350031	2
409	VITE FISSAG. ATTACCO	SCREW	VIS	TORNILLO	SCHRAUBE	300171	8
410	O RING	O RING	JOINT TORIQUE	JUNTA TORICA	O RING	100062	2
411	CILINDRETTO	BARREL	CANON	CUERPO	BUCHSE	0801401	1
412	O RING	O RING	JOINT TORIQUE	JUNTA TORICA	O RING	100162	1
413	PISTONCINO	SLIDE	PETIT PISTON	CORREDERA	VENTILKOLBEN	0801431	1
414	MOLLA	SPRING	RESSORT	MUELLE	FEDER	400121	1

HP 600.1 W / TP



LEGENDA ESPLOSO • PART LIST • LEGENDE ECLATEE • LEYENDA EXPLOSO • ERSATZTEILLISTE

	I	GB	F	E	D		
POS.	DESCRIZIONE	DESCRIPTION	DESCRIPTION	DESCRIPCION	BESCHREIBUNG	PART. N°	QUANT.
101	BLOCCO QUADRO	CHUCK HOUSING-BARE	GUIDE AVANT-NUE	FONDO-DESNUDO	VORDERZ.-ALLEIN	0701010A	1
103	SPINA ELASTICA	ELASTIC PIN	GOUJON ELASTIQUE	PASADOR ELASTICO	STIFT FUER BUCHSE	330071	2
104	BOCCOLA D'IMPATTO	SPACER	ENTRETOISE D'ARRET	CASQUILLO SUPERIOR	MEISSELBUCHSE HINTEN	0501040	1
106	INGRASSATORE	GREASE NIPPLE	GRAISSEUR	ENGRASADOR	SCHMIERNIPPEL	270011	1
108	FERMAUTENSILE	RETAINING AXLE	AXE DE RETENUE	RETENEDOR PICA	SPERRACHSE	0701081	2
110	SPINA ELASTICA	ELASTIC PIN	GOUJON ELASTIQUE	PASADOR ELASTICO	STIFT FUER BUCHSE	330121	1
117	O RING	O RING	JOINT TORIQUE	JUNTA TORICA	O RING	100173	4
152	BOCCOLA INF. WHISPER	CHUCK BUSH W	DOUILLE INFER. W	CASQUILLO INFER. W	MEISSELBUCHSE W	2301520	1
153	MANICOTTO PLASTICA	COMPOSITE BUSH	DOUILLE SYNTETIQUE	MANGUITO	MUFFE	2301530	1
154	ANELLO D'ARRESTO	CIRCLIP	BAGUE	ANILLO DE BLOQUE	BLOCKIERUNG RING	2301540	1
201	CILINDRO	CYLINDER	CYLINDRE	CILINDRO	ZYLINDER	0702016	1
204	GUARN. A LABBRO	"U" JOINT	JOINT À LEVRES	JUNTA "U"	"U" DICHTUNG	110031	2
206	VALVOLINA	VALVE	SOUPAPE	VALVULA	VENTIL	0302061	3
209	PISTONE MASSA	PISTON	PISTON	PISTON	SCHLAGKOLBEN	0702096	1
210	RIDUZIONE DI GUIDA	GUIDE ADAPTER	DOUILLE DE CENTRAGE	ADAPTADOR GUIA	FUHERUNGSBUCHSE	0702105	1
211	SPINA RIFERIMENTO	CENTERING PIN	GOUPILLE	PASADOR	STIFT	340121	1
301	TESTATA	HEAD	TETE	CABEZAL	KOPFTEIL	0703011	1
302	CORPO CASSETTO	DISTRIBUTOR BOX BODY	TIROIR DE DISTRIBUT.	CAJA DE DISTRIBUCION	STEUERGEHAUSE	0703025	1
303	O RING	O RING	JOINT TORIQUE	JUNTA TORICA	O RING	100151	2
304	DISTRIBUTORE FAST	DISTRIBUTOR FAST	DISTRIBUTEUR FAST	DISTRIBUIDOR FAST	STEUERVENTIL FAST	0703043	1
305	COPERCHIO AMMORTIZZAT.	SHOCK ABSORBER COVER	COUVERCLE ARMOTISSEUR	TAPA AMMORTIGUADOR	DAMPFER VERTEILERSCHEIBE	0703051	1
306	DIAFRAMMA AMMORTIZZAT.	STEEL DIAPHRAGM	DIAPHRAGME ARMOTISSEUR	DIAFRAGMA AMORTIGUADOR	DAMPFER DIAPHRAGMA	0703060	1
307	TIRANTE CON GOMMA	SIDE BOLT-RUBBER	VIS TIRANT-CAOUTC.	TIRANTE GOMA	SEITENSCHRAUBE-PLASTIK	0501140A	4
308	DADO PER TIRANTE	NUT	ECROU	TUERCA	MUTTER	0501130	4
309	O RING	O RING	JOINT TORIQUE	JUNTA TORICA	O RING	100112	1
401	ATTACCO	LINK	RACCORD	CONEXION	ANSCHLUSS-GEHAUSE	0604010	2
402	RONDELLA DI TENUTA	SEALING WASHER	RONDELLE D'ETANCHE	ANILLO DE SELLADO	DICHTUNGSSCHEIBE	120011	2
403	TAPPO 1/4" GAS	PLUG 1/4" GAS	BOUCHON 1/4" GAS	TAPON 1/4" GAS	STOPFEN 1/4" GAS	200011	2
404	RACCORDO 3/4"	CONNECTION 3/4"	RACCORD 3/4"	CONEXION 3/4"	3/4" ANSCHLUSS	1207140	2
406	O RING	O RING	JOINT TORIQUE	JUNTA TORICA	O RING	100032	4
407	RONDELLA	WASHER	RONDELLE	ARANDELA	SCHEIBE	1207190	2
408	SEEGER	SEEGER	SEEGER	RETENEDOR SEEGER	SPRENGRING	350031	2
409	VITE FISSAG. ATTACCO	SCREW	VIS	TORNILLO	SCHRAUBE	300171	8
410	O RING	O RING	JOINT TORIQUE	JUNTA TORICA	O RING	100062	2
411	CILINDRETTO	BARREL	CANON	CUERPO	BUCHSE	0801401	1
412	O RING	O RING	JOINT TORIQUE	JUNTA TORICA	O RING	100162	1
413	PISTONCINO	SLIDE	PETIT PISTON	CORREDERA	VENTILKOLBEN	0801431	1
414	MOLLA	SPRING	RESSORT	MUELLE	FEDER	400121	1

HP 600.1 - HP 600.1 W



ESPLOSO • EXPLODED VIEW • NUE ECLATEE • EXPLOSO • ERSATZTEIL-ZEICHNEN

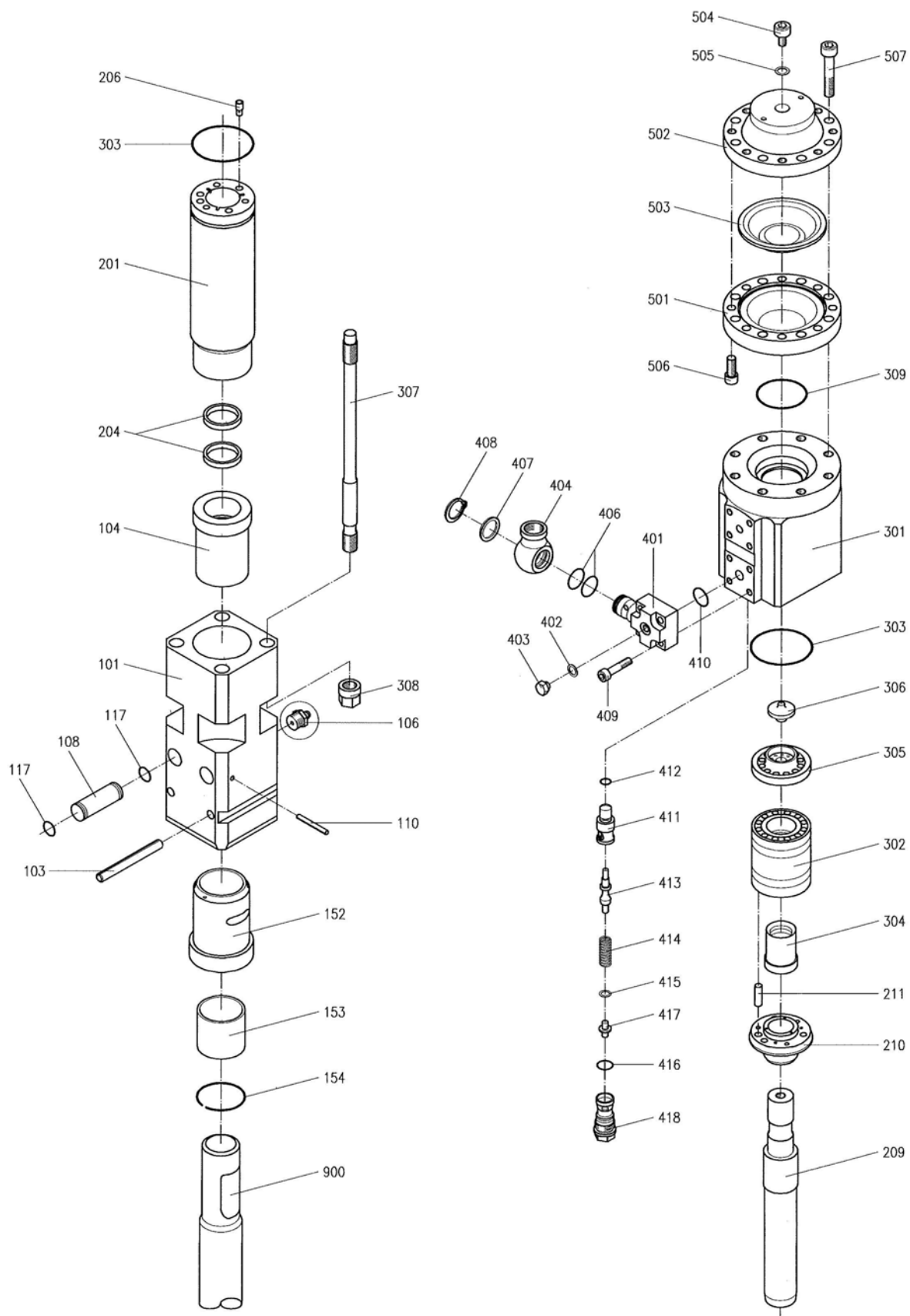

HP 600.1 TP

ESPLOSO • EXPLODED VIEW • NUE ECLATEE • EXPLOSO • ERSATZTEIL-ZEICHNEN

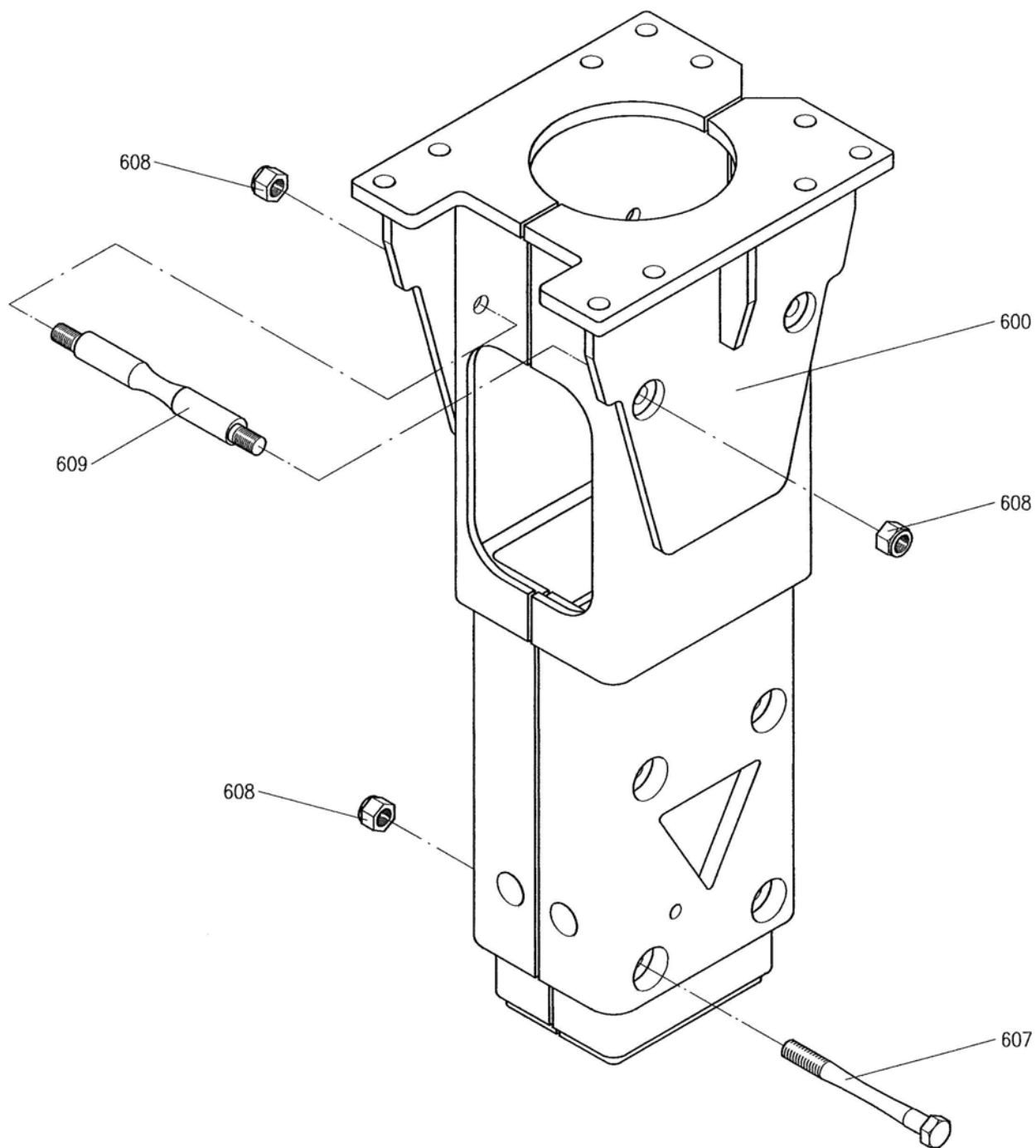

HP 600.1 W / TP



ESPLOSO • EXPLODED VIEW • NUE ECLATEE • EXPLOSO • ERSATZTEIL-ZEICHNEN

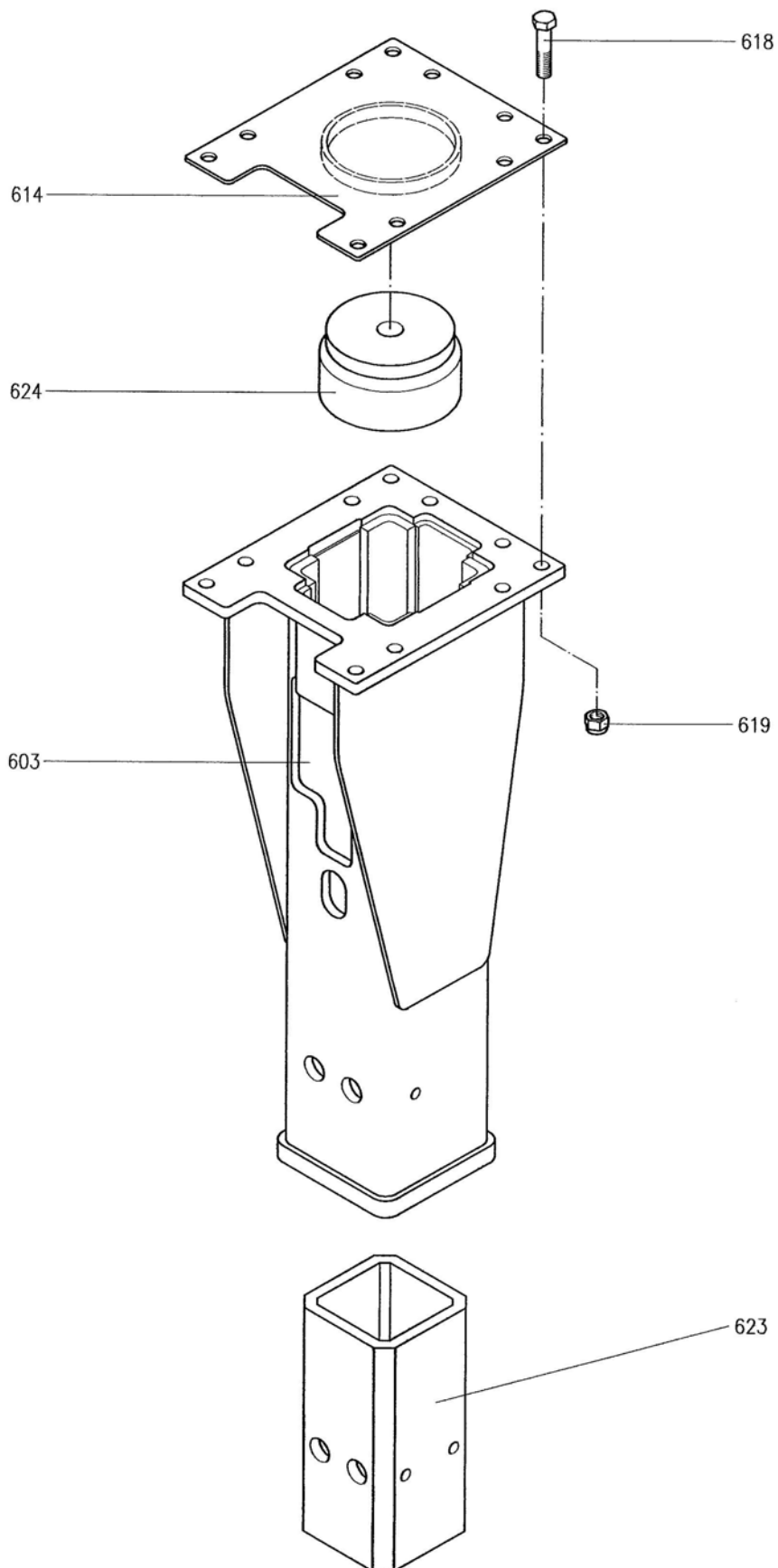

HP 600.1 TP



SPECIFICA TECNICA • TECHNICAL SPECIFICATION • SPECIFICATION TECHNIQUE • NOTA TECNICA • TECHNISCHE SPEZIFIKATION

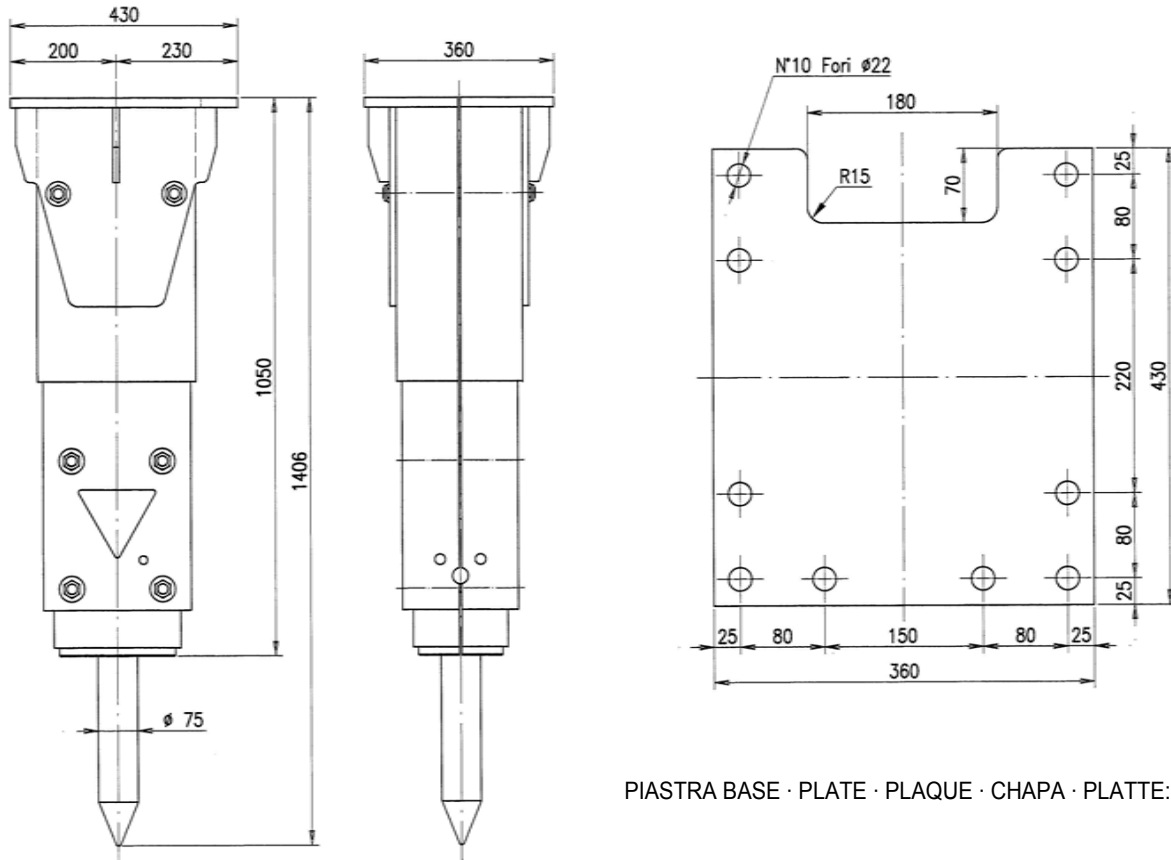

PIASTRA BASE · PLATE · PLAQUE · CHAPA · PLATTE: min. 25mm

I	GB	F	E	D	
PESO ESCAVATORE	SUITABLE ESCAVATOR	POIDS PELLE	PESO EXCAVADORA	GEEIGNET FÜR TRÄGERGERÄT	3,5 ÷ 10,5 ton
PESO OPERATIVO (CON SELLA E UTENSILE)	OPERATING WEIGHT (WITH MOUNTING BRACKET AND TOOL)	POIDS OPERATION (AVEC PLATINE ET OUTIL)	PESO OPERATIVO (CON CABEZAL E UTIL)	ARBEITSGEWICHT DES HAMMERS (MIT ADAPTERPLATTE UND MEISSEL)	390 kg
PESO (SENZA SELLA E UTENSILE)	OPERATING WEIGHT (WITHOUT MOUNTING BRACKET AND TOOL)	POIDS OPERATION (SANS PLATINE ET OUTIL)	PESO OPERATIVO (SIN CABEZAL E UTIL)	ARBEITSGEWICHT DES HAMMERS (OHNE ADAPTERPLATTE UND MEISSEL)	305 kg
DIAMETRO UTENSILE	STEEL DIAMETER	DIAMETRE OUTIL	DIAMETRO DE LA HERRAMIENTA	MEISSELDURCHMESSER	75 mm
ATTACCHI AL MARTELLO ENTRATA	HOSE CONNECTION AT THE BREAKERS INLET LINE	JOINTAGE AU BRISEROCHE ENTREE	DIAMETRO DE LA CONEXION ENTRADA AL MARTILLO	HAMMER-ANSCHLUSSSCHLAUCH VORLAUF	3/4" Gas
ATTACCHI AL MARTELLO USCITA	HOSE CONNECTION AT THE BREAKERS RETURN LINE	JOINTAGE AU BRISEROCHE SORTIE	DIAMETRO DE LA CONEXION SAIDA AL MARTILLO	HAMMER-ANSCHLUSSSCHLAUCH BÜCKLAUF	3/4" Gas
TUBAZIONE IMPIANTO (raccom.) TUBO MANDATA (min. in dia)	INLET LINE SIZE RECOMMENDATION (min.)	DIAMETRE TUYAN H.P. (min.)	DIAMETRO TUBO DE ENTRADA (min.)	VORLAUF-LEITUNGSGRÖSSE EMPFOHLEN (min.)	15 mm
TUBAZIONE IMPIANTO (raccom.) TUBO RITORNO (min. in dia)	RETURN LINE SIZE RECOMMENDATION (min.)	DIAMETRE TUYAN B.P. (min.)	DIAMETRO TUBO DE DESCARGA (min.)	RÜCKLAUF-LEITUNGSGRÖSSE EMPFOHLEN (min.)	16 mm
PORTATA DA EROGARE	OIL SUPPLY	DEBIT AU BRISEROCHE	CAUDAL DA SUMINISTRAR	ÖLBEDARF	50 ÷ 80 l/min
PRESSIONE REGOLATA AL MARTELLO	BREAKER WORKING PRESSURE	PRESSION REGLEE AU BRISE ROCHE	PRESION REGULADA AL MARTILLO	ARBEITSÖLDRUCK IM HYDRAULIKHAMMER	105 ÷ 130 bar
PRESSIONE REGOLATA ALL'ESCAVATORE	RELIEF PRESSURE SETTING	PRESSION REGLEE A LA PELLE	PRESION REGULADA A LA EXCAVADORA	ARBEITSÖLDRUCK VOM TRÄGERGERÄT	170 bar
CONTROPRESSIONE SUL MARTELLO (MAX)	BACK-PRESSURE AT THE BREAKER (MAX)	CONTRE PRESSION AU BRISE ROCHE (MAX)	CONTRAPRESION AL MARTILLO (MAX)	RÜCKLAUF-STAUDRUCK AM HYDRAULIKHAMMER (MAX)	11 bar
ENERGIA D'URTO (MAX)	IMPACT ENERGY (MAX)	PUISSANCE DE CHOC (MAX)	ENERGIA DE CHOQUE (MAX)	EINZELSCHLAG-ENERGIE (MAX)	720 Joule
NUMERO COLPI AL MINUTO	IMPACT RATE	FRAPPES PAR MINUTE	GOLPES AL MINUTO	SCHLAGZAHL PRO MINUTE	600 ÷ 1340 n/min
POTENZA INGRESSO (MAX)	INPUT POWER (MAX)	PUISSANCE ENTREE (MAX)	POTENCIA ENTRADA (MAX)	EINGANGS-GEWALT (MAX)	12,5 kw
VISCOSITÀ OLIO IDRAULICO	HYDRAULIC OIL VISCOSITY	VISCOSITE DE L'HUILE HIDR.	VISCOSODAD DELACEITE HIDR.	VISKOSITÄT DES HYDRAULIKÖLES	15 ÷ 90 Cst
LUNGHEZZA SUGGERITA TUBI FLESSIBILI	SUGGESTED MIN FLEX HOSES LENGHT	LONGUEUR DES FLEXIBLES	LARG. TUBOS FLEXIBLES	HAMMER-ANSCHLUSSSCHLAUCH LANGE	1400 mm

HP 600.1 W / TP



SPECIFICA TECNICA • TECHNICAL SPECIFICATION • SPECIFICATION TECHNIQUE • NOTA TECNICA • TECHNISCHE SPEZIFIKATION

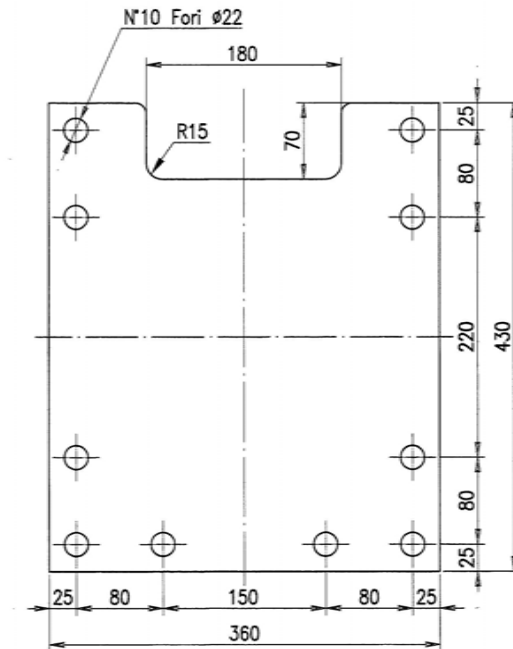
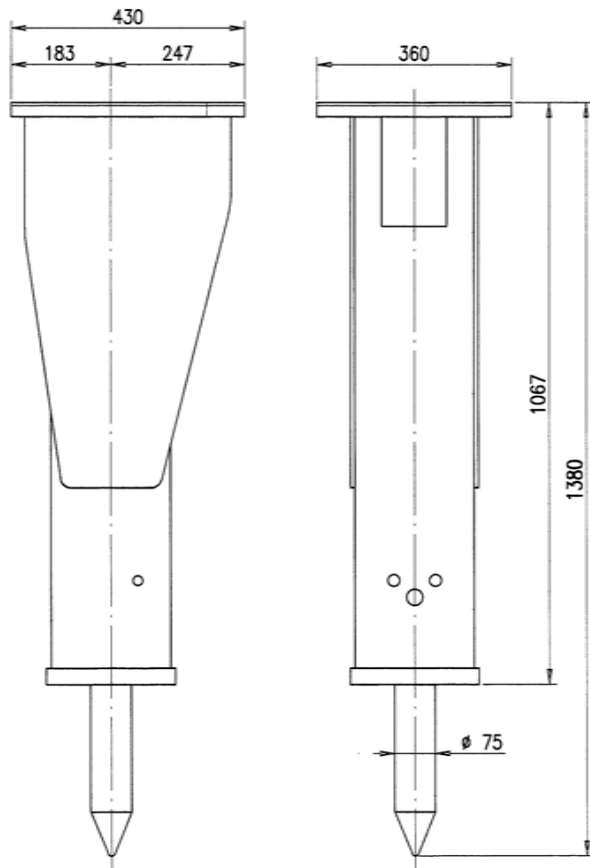

PIASTRA BASE · PLATE · PLAQUE · CHAPA · PLATTE: min. 25mm

I	GB	F	E	D	
PESO ESCAVATORE (CON SELLA E UTENSILE)	SUITABLE ESCAVATOR	POIDS PELLE	PESO EXCAVADORA	GEEIGNET FÜR TRÄGERGERÄT	3,5 ÷ 10,5 ton
PESO OPERATIVO (CON SELLA E UTENSILE)	OPERATING WEIGHT (WITH MOUNTING BRACKET AND TOOL)	POIDS OPERATION (AVEC PLATINE ET OUTIL)	PESO OPERATIVO (CON CABEZAL E UTIL)	ARBEITSGEWICHT DES HAMMERS (MIT ADAPTERPLATTE UND MEISSEL)	390 kg
PESO (SENZA SELLA E UTENSILE)	OPERATING WEIGHT (WITHOUT MOUNTING BRACKET AND TOOL)	POIDS OPERATION (SANS PLATINE ET OUTIL)	PESO OPERATIVO (SIN CABEZAL E UTIL)	ARBEITSGEWICHT DES HAMMERS (OHNE ADAPTERPLATTE UND MEISSEL)	305 kg
DIAMETRO UTENSILE	STEEL DIAMETER	DIAMETRE OUTIL	DIAMETRO DE LA HERRAMIENTA	MEISSELDURCHMESSER	75 mm
ATTACCHI AL MARTELLO ENTRATA	HOSE CONNECTION AT THE BREAKERS INLET LINE	JOINTAGE AU BRISEROCHE ENTREE	DIAMETRO DE LA CONEXION ENTRADA AL MARTILLO	HAMMER-AN- SCHLUSSSCHLAUCH VORLAUF	3/4" Gas
ATTACCHI AL MARTELLO USCITA	HOSE CONNECTION AT THE BREAKERS RETURN LINE	JOINTAGE AU BRISEROCHE SORTIE	DIAMETRO DE LA CONEXION SAIDA AL MARTILLO	HAMMER-AN- SCHLUSSSCHLAUCH BÜCKLAUF	3/4" Gas
TUBAZIONE IMPIANTO (raccom.) TUBO MANDATA (min. in dia)	INLET LINE SIZE RECOMMENDATION (min.)	DIAMETRE TUYAN H.P. (min.)	DIAMETRO TUBO DE ENTRADA (min.)	VORLAUF-LEITUNGSGRÖSSE EMPFOHLEN (min.)	15 mm
TUBAZIONE IMPIANTO (raccom.) TUBO RITORNO (min. in dia)	RETURN LINE SIZE RECOMMENDATION (min.)	DIAMETRE TUYAN B.P. (min.)	DIAMETRO TUBO DE DESCARGA (min.)	RÜCKLAUF-LEITUNGSGRÖSSE EMPFOHLEN (min.)	16 mm
PORTATA DA EROGARE	OIL SUPPLY	DEBIT AU BRISEROCHE	CAUDAL DA SUMINISTRAR	ÖLBEDARF	50 ÷ 80 l/min
PRESSIONE REGOLATA AL MARTELLO	BREAKER WORKING PRESSURE	PRESSION REGLEE AU BRISE ROCHE	PRESION REGULADA AL MARTILLO	ARBEITSÖLDRUCK IM HYDRAULIKHAMMER	105 ÷ 130 bar
PRESSIONE REGOLATA ALL'ESCAVATORE	RELIEF PRESSURE SETTING	PRESSION REGLEE A LA PELLE	PRESION REGULADA A LA EXCAVADORA	ARBEITSÖLDRUCK VOM TRÄGERGERÄT	170 bar
CONTROPRESSIONE SUL MARTELLO (MAX)	BACK-PRESSURE AT THE BREAKER (MAX)	CONTRE PRESSION AU BRISE ROCHE (MAX)	CONTRAPRESION AL MARTILLO (MAX)	RÜCKLAUF-STAUDRUCK AM HYDRAULIKHAMMER (MAX)	11 bar
ENERGIA D'URTO (MAX)	IMPACT ENERGY (MAX)	PUISSANCE DE CHOC (MAX)	ENERGIA DE CHOQUE (MAX)	EINZELSCHLAG-ENERGIE (MAX)	720 Joule
NUMERO COLPI AL MINUTO	IMPACT RATE	FRAPPES PAR MINUTE	GOLPES AL MINUTO	SCHLAGZAHL PRO MINUTE	600 ÷ 1340 n/min
POTENZA INGRESSO (MAX)	INPUT POWER (MAX)	PUISSANCE ENTREE (MAX)	POTENCIA ENTRADA (MAX)	EINGANGS-GEWALT (MAX)	12,5 kw
VISCOSITÀ OLIO IDRAULICO	HYDRAULIC OIL VISCOSITY	VISCOSITE DE L'HUILE HIDR.	VISCOSODAD DELACEITE HIDR.	VISKOSITÄT DES HYDRAULIKÖLES	15 ÷ 90 Cst
LUNGHEZZA SUGGERITA TUBI FLESSIBILI	SUGGESTED MIN FLEX HOSES LENGHT	LONGUEUR DES FLEXIBLES	LARG. TUBOS FLEXIBLES	HAMMER-AN- SCHLUSSSCHLAUCH LANGE	1400 mm

HP 600.1



COPPIE DI SERRAGGIO VITI E PRESSIONE CARICA AZOTO • TORQUE SETTING SCREWS AND NITROGEN CHARGING PRESSURE • COUPLE SERRAGE DES VIS ET PRESSION GONFLAGE AZOTE • PAR DE TORSION TORNILLOS Y PRESION CARGA DE NITROGENO • ANZUG DREHI MOMENT LADEN DRUCK STICKSTOFF

I	GB	F	E	D			
PARTICOLARE	PART	COMPOSANTE	PARTES	BESTANDTEIL	POS.	KEY	MKG
TIRANTE	SIDE BOLTS	TIRANT	TIRANTE	SETTENSCHRAUBE	308	32	48*
VITE VALVOLA PRESSIONE	GUIDING PLUG	BOUCHON GUIDE	TAPON GUIA	STOPFEN	418	30	50
VITE TAPPO TEST PRES.	1/4" PLUG	1/4" BOUCHON	1/4" TAPON	1/4" STOPFEN	403	19	4
VITE SERRAGGIO ATTACCO	SCREW	VIS D'ANCRAGE	TORNILLO	SCHRAUBE	409	B 10	7
VITE CARICAZOTO	INFLATING SCREW	VIS DE GONFLAGE	TORNILLO PARA INFLAR	FUELLSCHRAUBE STICKSTOFF	504	B 14	5
VITE ANCORAGGIO CAPSULA	FIXING SCREW	VIS D'ANCRAGE	TORNILLO FIJACION	VERSCHLUS-SCHRAUBE	507	B 14	16
VITE CHIUSURA CAPSULA	SELL FIXING SCREW	VIS DE FERMETURE	TORNILLO	SCHRAUBE	506	B 12	13
VITE ATTACCO SELLA	CRADLE SCREW	VIS POUR CHAPEAU	TORNILLO	SCHRAUBE FUER SATTEL	618	30	40
VITE CHIUSURA CARCASSA	CASING FIXING SCREW	VIS DE FERMETURE	TORNILLO	SCHRAUBE	607	30	43
DADO DISTANZIALE CARCASSA	NUT	ECROU	TUERCA	SCHRAUBE	608	30	30
PRESS. CARICA AZOTO OLIO 60°C	NITROGEN CHARGING PRESS. (AT OIL TEMP. 60°C)	PRESS. GONFLAGE AZOTE (TEMP. HUILE 60° C)	PRESION CARGA DE NITROGENO (ACEITE TEMP. 60° C)	LADEN DRUCK STICKSTOFF (OL TEMP. 60° C)	35 bars		
PRESS. CARICA AZOTO OLIO 70°C	NITROGEN CHARGING PRESS. (AT OIL TEMP. 70°C)	PRESS. GONFLAGE AZOTE (TEMP. HUILE 70° C)	PRESION CARGA DE NITROGENO (ACEITE TEMP. 70° C)	LADEN DRUCK STICKSTOFF (OL TEMP. 70° C)	30 bars		

* Il valore di coppia deve essere raggiunto gradatamente in più fasi di avvitamento e serrando a croce ed a rotazione.

* The indicated torque value must be reached gradually, screwing up the bolts in several phases by cross tightening and rotation.

* On doit atteindre la valeur de couple indiquée de manière graduelle, en plusieurs phases de vissage et en serrant à l'aide d'un tournevis en croix en plusieurs tours.

* El valor de acoplamiento indicado debe alcanzarse gradualmente atomillando en varias fases y apretando en forma de cruz y con un movimiento de rotación.

* Der Wert des Drehmomentes muss stufenweise in mehreren Verschraubungsphasen erreicht werden, indem Sie überkreuz und in Drehrichtung anschrauben.

HP 600.1 TP



LISTA COMPONENTI AGGIUNTIVI • PART LIST ACCESSORIES • LISTE DE LES ACCESSOIRES • LISTA DE COMPONENTES ADICIONAL • LISTE BAUELEMENT ZUSATZLICH

	I	GB	F	E	D		
POS.	DESCRIZIONE	DESCRIPTION	DESCRIPTION	DESCRIPCION	BESCHREIBUNG	PART. N°	QUANT.
	SELLA	CRADLE	PLATINE	CABEZAL	SATTEL	1210000	
618	VITE ATTACCO SELLA	CRADLE SCREW	VIS POUR CHAPEAU	TORNILLO	SCHRAUBE FUER SATTEL	310281	12
619	DADO AUTOBLOCCANTE	SELF LOCKING NUT	ECROU DE SURETE	TUERCA AUTOBLOCANTE	SCHRAUBENNUTTER	320031	12
	UTENSILE SCALPELLO	CHISEL	BURIN	CINCEL	FLACHMEISSEL	2309010AV	
	UTENSILE CONO	MOIL POINT	PIC	PICA	KEGELSPITZE	2309100AV	
	UTENSILE COBRA	COBRA TOOL	OUTIL COBRA	UTIL COBRA	COBRA MEISSEL		
	UTENSILE	TOOL	OUTIL	UTIL	MEISSEL		
	KIT INGRASSAGGIO	KIT AUTOLUBE	KIT DE GRAISSAGE	KIT DE ENGRASE	SCHMIERZENTRALE		
	KIT SUB	KIT UNDER WATER	KIT SOUS MARINE	KIT SUBMARINO	KIT UNTERWASSER		
	KIT CARICA AZOTO	NITROGEN INFLATING KIT	KIT LE GONFLAGE	EQUIPO CARGA NITROGENO	STICKSTOFF SPEICHLR	2720000C	
	ELETTROVALVOLA	SOLENOID VALVE	SOUPAPE ELECTRIQUE	ELECTRO VALVULA	ELEKTRISCHER VENTIL		
	PEDALIERA	FOOT SWITCH	INTERRUPTEUR À PEDAL	INTERRUPTOR DE PIE	FUSSGEBER		
	KIT IDRAULICO	HYDRAULIC KIT	KIT HYDRAULIQUE	KIT HIDRAULICO	HYDRAULIK ANSCHLUSS		
	TUBO MANDATA DEMOLITORE	INLET PIPE	TUYAN H.P.	TUBO DE ALIMENTACION	HD-SCHLÄUCHE	500111	
	TUBO RITORNO DEMOLITORE	OUT LET PIPE	TUYAN B.P.	ND-SCHLÄUCHE	ND-SCHLÄUCHE	500112	

HP 600.1 W / TP



LISTA COMPONENTI AGGIUNTIVI • PART LIST ACCESSORIES • LISTE DE LES ACCESSOIRES • LISTA DE COMPONENTES ADICIONAL • LISTE BAUELEMENT ZUSATZLICH

	I	GB	F	E	D		
POS.	DESCRIZIONE	DESCRIPTION	DESCRIPTION	DESCRIPCION	BESCHREIBUNG	PART. N°	QUANT.
	SELLA	CRADLE	PLATINE	CABEZAL	SATTEL	0610000	
618	VITE ATTACCO SELLA	CRADLE SCREW	VIS POUR CHAPEAU	TORNILLO	SCHRAUBE FUER SATTEL	310411	10
619	DADO AUTOBLOCCANTE	SELF LOCKING NUT	ECROU DE SURETE	TUERCA AUTOBLOCANTE	SCHRAUBENNUTTER	320031	10
	UTENSILE SCALPELLO	CHISEL	BURIN	CINCEL	FLACHMEISSEL	2309010AV	
	UTENSILE CONO	MOIL POINT	PIC	PICA	KEGELSPITZE	2309100AV	
	UTENSILE COBRA	COBRA TOOL	OUTIL COBRA	UTIL COBRA	COBRA MEISSEL		
	UTENSILE	TOOL	OUTIL	UTIL	MEISSEL		
	KIT INGRASSAGGIO	KIT AUTOLUBE	KIT DE GRAISSAGE	KIT DE ENGRASE	SCHMIERZENTRALE		
	KIT SUB	KIT UNDER WATER	KIT SOUS MARINE	KIT SUBMARINO	KIT UNTERWASSER		
	KIT CARICA AZOTO	NITROGEN INFLATING KIT	KIT LE GONFLAGE	EQUIPO CARGA NITROGENO	STICKSTOFF SPEICHLR	2720000C	
	ELETTROVALVOLA	SOLENOID VALVE	SOUPAPE ELECTRIQUE	ELECTRO VALVULA	ELEKTRISCHER VENTIL		
	PEDALIERA	FOOT SWITCH	INTERRUPTEUR À PEDAL	INTERRUPTOR DE PIE	FUSSGEBER		
	KIT IDRAULICO	HYDRAULIC KIT	KIT HYDRAULIQUE	KIT HIDRAULICO	HYDRAULIK ANSCHLUSS		
	TUBO MANDATA DEMOLITORE	INLET PIPE	TUYAN H.P.	TUBO DE ALIMENTACION	HD-SCHLÄUCHE	500111	
	TUBO RITORNO DEMOLITORE	OUT LET PIPE	TUYAN B.P.	ND-SCHLÄUCHE	ND-SCHLÄUCHE	500112	